

PCAN-MIO

Universal Controller for
CAN Applications

User Manual



Document version 1.11.3 (2017-02-20)

PEAK
System

Relevant products

Product Name	Model	Part number
PCAN-MIO	Industrial connector (Phoenix)	IPEH-002187
PCAN-MIO	Automotive connector (Tyco)	IPEH-002187-A

Product names mentioned in this manual may be the trademarks or registered trademarks of their respective companies. They are not explicitly marked by “™” and “®”.

© 2017 PEAK-System Technik GmbH

PEAK-System Technik GmbH
Otto-Roehm-Strasse 69
64293 Darmstadt
Germany

Phone: +49 (0)6151 8173-20
Fax: +49 (0)6151 8173-29

www.peak-system.com
info@peak-system.com

Document version 1.11.3 (2017-02-20)

Contents

1	Introduction	5
1.1	Properties at a Glance	6
1.2	Prerequisites for Operation	7
1.3	Scope of Supply	7
2	Function Characteristics of the Basic Module	8
2.1	Supply	8
2.2	Analog Inputs	9
2.3	Analog Outputs	9
2.4	Digital Inputs	10
2.5	Digital Outputs	10
2.6	Function Blocks	11
2.7	PPCAN Protocol	12
2.8	Module Reset	12
3	Operation	13
3.1	Module Settings	13
3.2	Basic Connections	15
3.3	Output States at Power-up	16
3.4	Software Installation	16
3.5	Altered Configuration Structure from Serial Number 100	18
4	Front Panel Elements	20
4.1	Pin Assignment	20
4.1.1	Industrial Connector (Phoenix)	20
4.1.2	Automotive Connector (Tyco)	23
4.2	CAN Bus Termination (Switch)	25
4.3	Module ID (Rotary Switch)	26
4.4	Status LED	27

5	Alternative CAN Transceiver Modules	28
6	Technical Specifications	30
Appendix A	CE Certificate	33
Appendix B	Dimension Drawings	34
Appendix C	Module Resources	36

1 Introduction

The **Multiple Input Output** module (MIO) is supplied as a universal, modular control unit in the mid-range performance class. It is designed to be used in both **industrial** and **automotive** applications.

The basic module provides a mixed **analog and digital functionality**. A bus structure also permits adding modules to expand the number of inputs and outputs. This permits implementing individual customer requirements. As many as six additional modules are possible (Modifications of the housing and the front plate are generally necessary).

Signals and data can be modified and linked by the microcontroller in a **wide variety of** ways. A large number of what is referred to as function blocks are available (see section 2.6 Seite 11).

The inputs and outputs, i.e., the behavior of the PCAN-MIO module can **be configured using software which runs on the Windows operating system**. A configuration from the PC to the PCAN-MIO module is transmitted via a CAN bus.

The PCAN-MIO module has two **CAN channels**, which can be adapted with internal plug-in modules (transceivers) to various physical CAN transmission standards. Between the two CAN channels it is possible for CAN messages to be exchanged via the **gateway function**.

The basic module is combined with a vertically arranged connector board and an **all-metal** housing. As an option a DIN rail mounting is also possible. An alternative connector board enables inputs and outputs of the basic module to be adapted to specific target system requirements.

1.1 Properties at a Glance

- └ 2 High-speed CAN channels via pluggable transceiver modules
- └ Low-speed, Single-wire, and opto-decoupled High-speed modules, as well as High-speed modules without wake-up function alternatively available
- └ Wake-up via a separate input or the CAN bus
- └ CAN termination switchable
- └ 8 digital inputs with low-pass performance
- └ 8 digital outputs, 2 of them PWM-capable
- └ 6 analog inputs (10 bit, 1 kHz, 0 - 10 V)
- └ 2 analog outputs (10 bit, 0 - 10 V)
- └ Suitable for use in automotive applications
- └ Comprehensive configuration with the Windows software PPCAN-Editor 2
- └ Module can store up to 15 configurations
- └ CAN gateway between the buses
- └ Various function blocks for data linking and modification
- └ Industrial connectors (Phoenix spring terminal connectors) or automotive connectors (Tyco connectors)
- └ Aluminum profile casing with mounting flange
- └ DIN rail mounting option on request
- └ Voltage supply 9 - 27 V, overvoltage and reversed polarity protection
- └ Extended operating temperature range of -40 to +85°C (-40 to +185 °F)

1.2 Prerequisites for Operation

- └ Power source, nominal 12 V, 9 - 27 V possible
- └ For configuring via CAN:
 - Computer with CAN interface of the PCAN series (PCAN-USB is part of the optionally available Set)
 - CAN cabling with correct termination
 - Windows 10, 8.1, and 7 (32/64-bit) for the configuration program

1.3 Scope of supply

- └ PCAN-MIO basic module in aluminum casing
- └ 4 terminal strip plugs (industrial model IPEH-002187)
- └ 32-pole and 12-pole plug with crimp contacts (automotive model IPEH-002187-A)
- └ Configuration software PPCAN-Editor 2 for Windows
- └ Documentation in PDF format
- └ CAN interface PCAN-USB with order of the Set

2 Function Characteristics of the Basic Module

This chapter describes the essential functional characteristics of the PCAN-MIO basic module.

There is a list of all logical resources (I/O function, I/O number) which are provided by the PCAN-MIO module in the Appendix C Seite 36.

2.1 Supply

The internal 5-Volt supply is provided by a switching regulator. This regulator also meets the 5-Volt needs of additional boards and external low-power consumers such as sensors. The dimensioning covers an overall need of 2 A.

At the power input protection is provided against overvoltage and reversed polarity. With the help of two internal control lines the microcontroller can switch internal consumers on or off and activate self-holding. To handle brownouts, a comparator checks the internal 5-Volt supply and triggers a reset if necessary (smaller than 4.35 V). The CAN transceiver modules are wake-up-capable and are permanently supplied with input voltage.

The PCAN-MIO module can be activated by an external control connection as an alternative to the CAN wake-up. After booting, the microcontroller itself can control the power supply by means of the mentioned self-holding. External sensors are supplied with 5 V, protected and loadable to a max. of 500 mA. In case of a short-circuit the continued work of the microcontroller is assured by the decoupling of the internal 5-Volt supply. A reference of 5 V is provided for analog, internal use.

2.2 Analog Inputs

There are six analog inputs with pull-down circuit (12 k Ω), low-pass performance and overvoltage protection. The standard measurement range is from 0 to 10 V. Analog measurements are unipolar, single-ended, have a resolution of 10 bit (A/D converter) and referenced to a 5 V, 0.2 % accuracy and a temperature coefficient of 20 ppm.

The measurement range for the individual inputs can be adapted by a voltage divider. Regarding this subject please contact PEAK-System (contact information: see Seite 2).

2.3 Analog Outputs

The two analog outputs are derived from a 10-bit D/A converter. The standard output voltage is 0 to 10 V for a maximum current drain of 20 mA. The outputs are short-circuit-proof. As an option, instead of the internal reference of 5 V, the supply voltage V_E can be specified as a reference (hardware modification required). In this case, the internal reference is 1/3 of the supply voltage V_E , however, it is limited to 5.1 V.

The internal reference is used as a standard. Regarding the optional external reference please contact PEAK-System (contact information: see Seite 2).

2.4 Digital Inputs

There are eight digital inputs with low-pass performance and hysteresis behavior. In groups with one, two or three inputs, at the inputs DIN0 to DIN5, pull-down resistors can be connected, for example for contacts. At the DIN6 and DIN7 inputs only one pull-up circuit is available.

The switch thresholds are 4 V (High) and 3 V (Low). For the power-save mode the pull-up circuits can be shut down by the microcontroller. The inputs DIN0 to DIN4 are connected directly to the input-capture pins of the microcontroller as fast inputs to determine frequencies and the duty cycles. The DIN5 to DIN7 inputs are for the static status recognition (max. possible switching frequency: approx. 1 kHz).

2.5 Digital Outputs

The eight digital outputs are subdivided into six protected, statically addressable low-power switches (DOUT2 to DOUT7, max. 0.6 A) and two protected, PWM-capable high-side switches (DOUT0 and DOUT1, max. 1.4 A). The high-side switches are allocated to PWM-capable timer outputs (HW-PWM). In the case of the low-power switches, a configuration can be used to decide for each output whether it should work as high-side or low-side switch or be inactive. When used as low-side switch, an output can be operated with up to 30 V against ground.

The protective measures relate to excessive voltage, current, and temperature. The high-side switch is supplied with power directly from the module's power connection. Protection is provided against reverse poling of the supply voltage.

2.6 Function Blocks

This table is an overview of the various function blocks available for processing the data with the microcontroller.

You can obtain details about the individual function blocks from the reference tables which come with the configuration program PPCAN-Editor for Windows which is included in the delivery.

Function block	Description
Identity	Copies the input variable to the output variable.
Scaling	Conversion of an input value, with multipliers and offset; the result is copied into the output variable.
Hysteresis	The output is dependent on the input value set to one of two pre-defined values.
Monoflop	The output is set to one of two pre-defined values depending on the input value for a pre-defined period.
Extended Hysteresis	Depending on an input value the output is timeout activated for a pre-defined period (set to 1). A second input acts as an enable signal.
Switch Delay	Switch-on, switch-off delay or a combination of the two.
Lowpass	Realization of a lag element by a low-pass with an adjustable time.
Characteristic Curve	The input signal is converted by applying a pre-defined characteristic curve.
Characteristic Curve with Limit	Like the characteristic curve but in this case values specified outside the characteristic curve are returned.
Characteristic Map	The input signal is converted using a pre-defined surface which is composed from a list of characteristic curves.
Characteristic Map with Limit	Like the characteristic map but in this case values specified outside the surface are returned.
Small Map	The two inputs indicate a position within a grid of 12 fields. The return values of the fields are specified by the default assignment tables.
Ramp Counter	Each time a function is called the counter counts one more step from a lower to an upper limit and then begins again at the lower value.
Counter with Clock and Reload Input	Counter for flanks to an input

Function block	Description
PI Element	Simple PI regulator with reference and actual value inputs
PIDT1 Element	PIDT1 regulator
Difference	Help function block for the PIDT1 regulator
Math Function	Collection of various mathematical and logical functions
Binary Field	Compiles a sequence of digital data into a binary value.

2.7 PPCAN Protocol

The PCAN-MIO module is configured via a connected CAN bus per PPCAN protocol (point-to-point CAN), a development achieved by PEAK-System Technik GmbH. The PPCAN protocol permits as a principle the data communication between two specified CAN nodes, i.e., CAN data are transmitted to a specific target. In this way configuration data transmissions can be directed to one PPCAN-capable module or to a transmitted PCAN-MIO module on the CAN bus.



Note: The PPCAN protocol uses the **CAN ID 7E7h** for communication. Do not use this CAN ID for further communication of CAN nodes in a net.

2.8 Module Reset

The module has no separate switch or input for a reset. You can reset the PCAN-MIO module by separating it for a short time from the supply. An option for switching off, for example, is the selfhold function controlled via CAN, the subsequent restart can be triggered by a wake-up signal.

3 operation

This chapter describes the preparations necessary to ensure that the PCAN-MIO module can receive and transmit data via a connected CAN bus. This section does not yet discuss how to create and apply a configuration. There is a guide on this subject in the help pages provided with the Windows-based PPCAN-Editor.

The description assumes that you initially connect only one PCAN-MIO module via a High-speed CAN bus to a PC with a Windows operating system.

Please read through all the sections in this chapter.

3.1 Module Settings

Settings for the module ID and a CAN termination can be made using switches on the PCAN-MIO module.

Please check that the rotary switch for the **Module ID** is set to **0**.

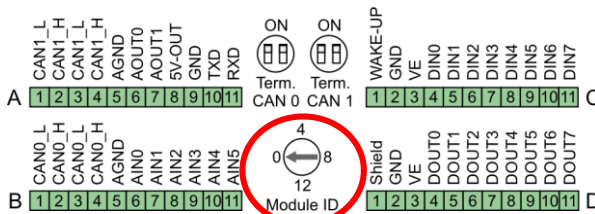

Rotary switch for the module ID on the front plate of the industrial model

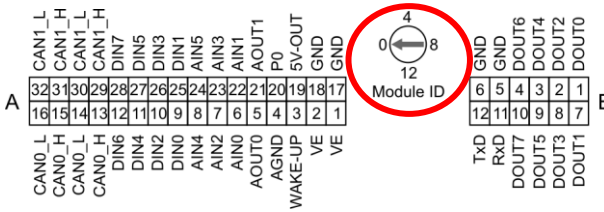

Rotary switch for the module ID on the front plate of the automotive model

Since in the assumed case the PCAN-MIO module is the sole node on the High-speed CAN bus connected via a direct line to the CAN interface of a PC, the **termination** must be activated. The two DIP switches on the switch block for CAN 0 must be in the upper position **ON**.

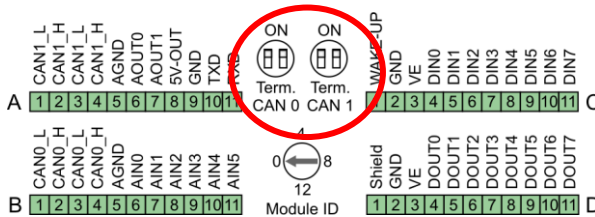

Switch blocks for the CAN bus termination on the front plate of the industrial model

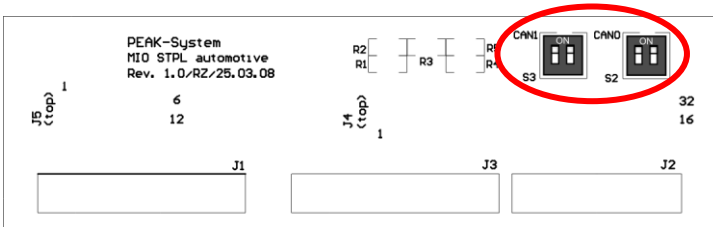

Switch blocks for the CAN bus termination (automotive model), rear side of the connector board when the PCAN-MIO housing is open

3.2 Basic Connections

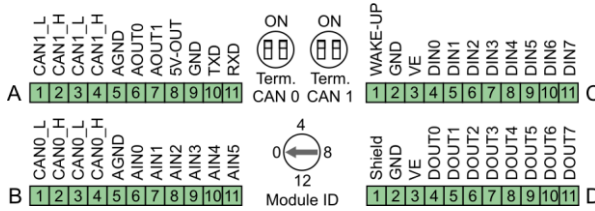

Connector pin assignment industrial model

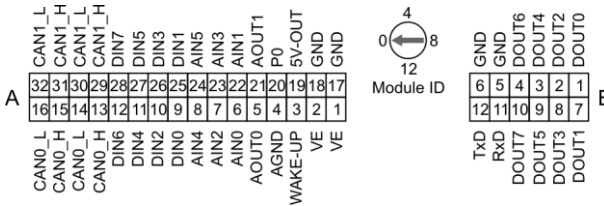

Connector pin assignment automotive model

The following pins are used to connect the **CAN bus**:

Line	Connection Industrial	Connection Automotive	Comment
CAN0_L	B1/B3	A14/A16	Ports with the same signal name are internally connected.
CAN0_H	B2/B4	A13/A15	

The operation of the PCAN-MIO module requires a **voltage source** with a nominal 12 V direct current (9 - 27 V possible). The connection is made using these pins:

Line	Connection Industrial	Connection Automotive	Comment
GND	C2/D2	A17/A18	Ports with the same signal name are internally connected.
VE	C3/D3	A1/A2	

When supply voltage is present, the module starts operation only on a wake-up signal. Depending on the CAN transceiver equipment

this happens automatically, or you have to apply a High stage to the external wake-up line.

Line	Connection Industrial	Connection Automotive
WAKE-UP	C1	A3

The PCAN-MIO module has started operation when the **status LED** blinks green.

3.3 Output States at Power-up

After powering up the module and before a configuration is read from the EEPROM the outputs have the following states:

Outputs	State
DOUT	high impedance (tri-state)
AOUT	0 V
5V-OUT	high impedance (tri-state)

3.4 Software Installation

The module is configured using the included PPCAN-Editor, which runs on a Windows platform, via a CAN bus connection between the computer and the PCAN-MIO module.

▶ This is how to install the PPCAN-Editor:

1. Only Windows XP: Make sure that you are logged in as user with administrator privileges.

When you use the PPCAN-Editor later you can also work as a user with limited rights.

2. Start the setup program from the supplied CD, directory Tools/PPCAN-Editor.

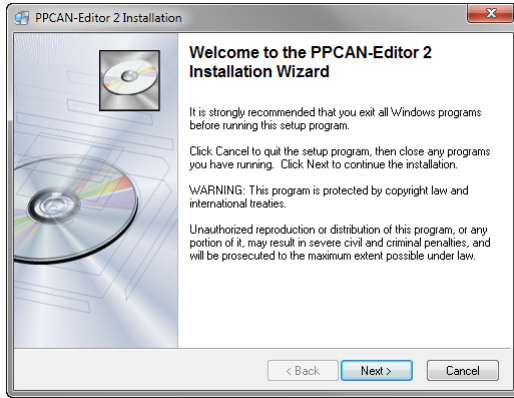

Startup screen of the installation program for the PPCAN-Editor

3. Follow the instructions of the setup program until you come to the step **Select Hardware Profiles**. At this point select at least both entries for the PCAN-MIO module so that it will be supported by the PPCAN-Editor.

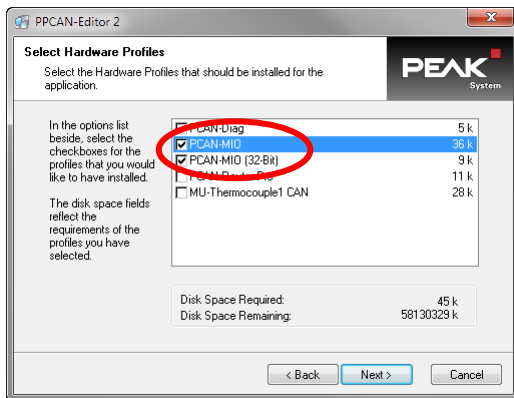

Selection of the hardware profile for the PCAN-MIO module

4. Follow the remaining instructions of the setup program.

You can then launch the PPCAN-Editor, create a configuration, and transmit this to the PCAN-MIO module. Find relevant information in the help of the PPCAN-Editor. See also some introductory video tutorials to the PPCAN-Editor in the Support area on our website (www.peak-system.com).



Note: The PPCAN-Editor uses the **CAN ID 7E7h** for communication with the PCAN-MIO module. Do not use this CAN ID for further communication of CAN nodes in a net.

3.5 Altered Configuration Structure from Serial Number 100

From serial number 100 PCAN-MIO modules work with an internally altered configuration structure. Therefore, at creation of a new configuration in the PPCAN-Editor you must select the appropriate hardware profile:

PCAN-MIO serial number	MIO hardware profile to be used
up to 99	PCAN-MIO
from 100	PCAN-MIO (32-Bit)

Configurations being created based on the other MIO hardware profile cannot be directly sent to a PCAN-MIO module.



Do the following to adapt a configuration to another MIO hardware profile:

1. In the PPCAN-Editor open the present MIO configuration.
2. Select the menu command **Edit > New Configuration**.

The window for selecting a hardware profile is shown.

3. Depending on the MIO hardware profile used presently select the other one. When updating to a PCAN-MIO module with serial number 100 and up, this is **\$1B PCAN-MIO (32-Bit)**, in the vice versa case accordingly **\$14 PCAN-MIO**.
4. Create the module-specific CAN configuration on the new tab in the window **CAN Objects**. This is done on basis of the **General CAN** objects. When matching the entries, you can use the previous module-specific CAN configuration for orientation.
5. Open the configuration windows of the previous and the new configuration (**Config XY**).
6. From each tab of the present configuration, copy all entries onto the tab of the new one. You can use the known key shortcuts for selecting, copying, and inserting under Windows.
7. In the **CAN Objects** window, delete the former configuration by executing the corresponding context menu command on the configuration's tab.



Note: New I/O functions which are only available in the hardware profile “\$1B PCAN-MIO (32-Bit)” cannot be copied to configurations based on the profile “\$14 PCAN-MIO”.

4 Front Panel Elements

This chapter describes the elements present on the front of the PCAN-MIO module housing. They involve connections, the switches for the CAN bus termination, the rotary switch to set the module ID and the status LED.

If you use an alternative plug-in board with a modified front panel, the elements may be different from the standard elements mentioned here.

4.1 Pin Assignment

This section describes the functional assignment of all pin connections. There is a list of all logical resources (I/O function, I/O number) which are provided by the PCAN-MIO module in the Appendix C Seite 36.

Ports with the same signal name are internally connected.

4.1.1 Industrial Connector (Phoenix)

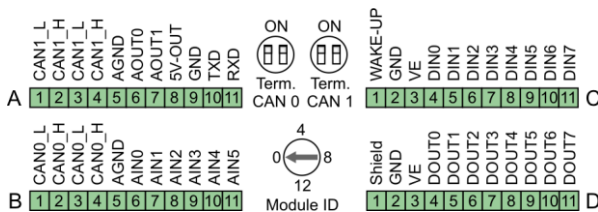

Connector pin assignment of the industrial model

	Name	Use	More info
A			
1	CAN1_L	CAN connection transceiver 1	Connected to pin 3; at Single-wire CAN not connected
2	CAN1_H		Connected to pin 4
3	CAN1_L		Connected to pin 1; at Single-wire CAN not connected
4	CAN1_H		Connected to pin 2
5	AGND	Ground analog, reference for AOUT and AIN	
6	AOUT0	Analog Output 0 - 10 V, 20 mA, 10 bit	Only source
7	AOUT1		
8	5V-OUT	5 V, 500 mA	
9	GND	Ground, reference for digital and power supply	
10	TXD	RS-232	
11	RXD		
B			
1	CAN0_L	CAN connection transceiver 0	Connected to pin 3; at Single-wire CAN not connected
2	CAN0_H		Connected to pin 4
3	CAN0_L		Connected to pin 1; at Single-wire CAN not connected
4	CAN0_H		Connected to pin 2
5	AGND	Ground analog, reference for AOUT and AIN	
6	AIN0	Analog input 0 - 10 V	13.6 k Ω input impedance
7	AIN1		
8	AIN2		
9	AIN3		
10	AIN4		
11	AIN5		

	Name	Use	More info
C			
1	WAKE-UP	Digital input for wake-up signal	High (> 4.0 V) = module on
2	GND	Ground, reference for digital and power supply	
3	VE	Power supply 9 - 27 V DC	
4	DIN0	Digital input, optional determination of frequencies and duty cycles	High > 4.0 V, Low < 3.0 V 5 - 10,000 Hz Pull-up/Pull-down: up to ser. no. 99 by jumpers on the board (on request), from ser. no. 100 by configuration
5	DIN1		
6	DIN2		
7	DIN3		
8	DIN4		
9	DIN5	Digital input (static status detection)	Max. processible switch frequency < 500 Hz
10	DIN6		
11	DIN7		
D			
1	Shield	Shield	
2	GND	Ground, reference for digital and power supply	
3	VE	Power supply 9 - 27 V DC	
4	DOUT0	Digital output, high-side driver 5 A short circuit	Optional FOUT/PWM OUT with maximum frequency
5	DOUT1		
6	DOUT2	Digital output 0.6 A each 1.4 A together	Useable as high-side, low-side, or push-pull driver (by configuration) Low-side: max. 30 V against GND
7	DOUT3		
8	DOUT4		
9	DOUT5		
10	DOUT6		
11	DOUT7		

4.1.2 Automotive Connector (Tyco)

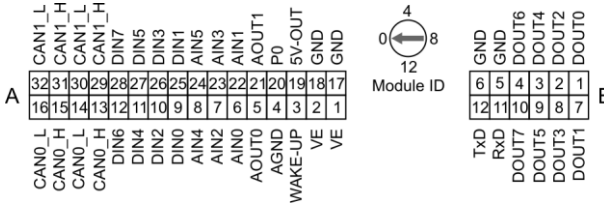

Connector pin assignment of the automotive model

	Name	Use	More info
A			
1	VE	Power supply 12 V DC	KL30
2			
17	GND	Ground, reference for digital and power supply	KL31
18			
3	WAKE-UP	Digital input for wake-up signal	High (> 4.0 V) = module on
19	5V-OUT	5 V, 500 mA	
4	AGND	Ground analog, reference for AOUT and AIN	
20	P0	Reserved	
5	AOUT0	Analog Output 0 - 10 V, 20 mA, 10 bit	Only source
21	AOUT1		
6	AIN0	Analog input 0 - 10 V	Pull-down circuit 12 kΩ, optional pull-up circuit to 5V-OUT
22	AIN1		
7	AIN2		
23	AIN3		
8	AIN4		
24	AIN5		Pull-down circuit 12 kΩ
9	DIN0	Digital input, optional determination of frequencies and duty cycles	High > 4.0 V, Low < 3.0 V 5 - 10,000 Hz Pull-up/Pull-down: up to ser. no. 99 by jumpers on the board (on request), from ser. no. 100 by configuration
25	DIN1		
10	DIN2		
26	DIN3		
11	DIN4		

	Name	Use	More info
27	DIN5	Digital input (static status detection)	Max. processible switch frequency < 500 Hz
12	DIN6		
28	DIN7		
13	CAN0_H	CAN connection transceiver 0	Connected to pin 15
14	CAN0_L		Connected to pin 16; at Single-wire CAN not connected
15	CAN0_H		Connected to pin 13
16	CAN0_L		Connected to pin 14; at Single-wire CAN not connected
29	CAN1_H	CAN connection transceiver 1	Connected to pin 31
30	CAN1_L		Connected to pin 32; at Single-wire CAN not connected
31	CAN1_H		Connected to pin 29
32	CAN1_L		Connected to pin 30; at Single-wire CAN not connected
B			
1	DOUT0	Digital output, high-side driver 5 A short circuit	Optional FOUT/PWM OUT with maximum frequency
7	DOUT1		
2	DOUT2	Digital output 0.6 A each 1.4 A together	Useable as high-side, low-side, or push-pull driver (by configuration) Low-side: max. 30 V against GND
8	DOUT3		
3	DOUT4		
9	DOUT5		
4	DOUT6		
10	DOUT7		
5	GND	Ground, reference for digital and power supply	KL31
6			
11	RxD	RS-232	
12	TxD		

4.2 CAN Bus Termination (Switch)

Depending on the used CAN transceiver module you can activate or change a CAN bus termination with the corresponding switch blocks. Switches 1 and 2 on a switch block always must have the same position. By default the switches are in OFF position (lower position according to the orientation of the figure). The assignment of switch block to CAN channel is visible from the respective labeling (CAN channels CAN0 and CAN1).

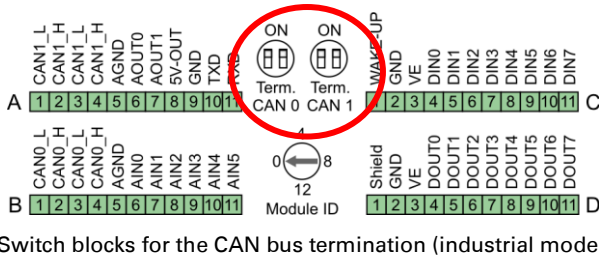

Switch blocks for the CAN bus termination (industrial model)

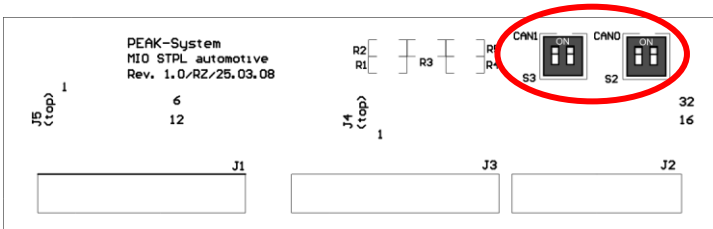

Switch blocks for the CAN bus termination (automotive model), rear side of the connector board when the PCAN-MIO housing is open

Type of transceiver	Termination at switch position*	
	OFF (standard)	ON
High-speed CAN (ISO 11898-2)	none	120 Ω between CAN_L and CAN_H
Low-speed CAN (ISO 11898-3)	4.7 kΩ for CAN_L and CAN_H	1.1 kΩ for CAN_L and CAN_H
Single-wire CAN (SAE J2411)	9.1 kΩ for CAN_SW	2.1 kΩ for CAN_SW

* Both switches of a switch block

4.3 Module ID (Rotary Switch)

The rotary switch has 16 rest positions to determine the module ID (0 - F hex = 0 - 15). The position for ID 0 is to the left. The model IDs increase in a clockwise direction.

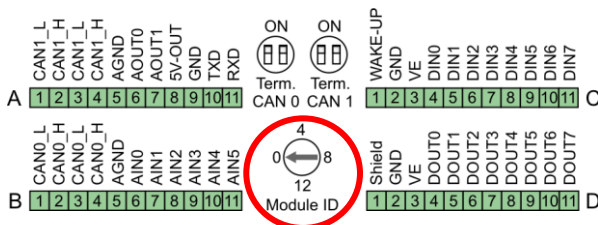

Rotary switch for the module ID (industrial model)

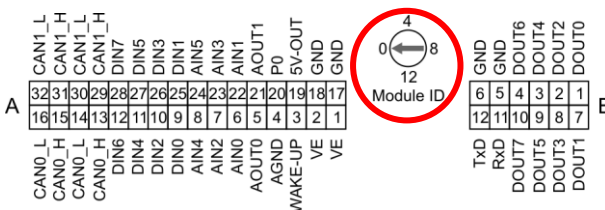

Rotary switch for the module ID (automotive model),
remove cover plug if present

When the PCAN-MIO module is started the **configuration** with the number from the internal memory is loaded which matches the specified module ID (from ser. no. 100 excluding module ID 15). In addition, with the module ID there is a unique **identification** of the PCAN-MIO module during the PPCAN communication (configuration transfer). For the transmission of CAN messages in normal operation this module ID is not relevant.

From serial number 100 the **module ID 15** is reserved for the case of a firmware update failure so that there's still a possibility to access the PCAN-MIO module. At this setting a CAN bootloader is ready after a module reset. See also the separate documentation for a firmware update via CAN (on request).

➤ This is how you change the module ID of a PCAN-MIO module:

1. Change the position of the rotary switch with a small slot screwdriver.
2. Restart the module by briefly interrupting the power supply.

After the restart the changed module ID will be active.
Before the restart changes made at the rotary switch will have no influence on operation.



Tip: If the communication with the PCAN-MIO module is prevented because you do not know the bit rates used by the CAN channels, you can set the module ID to a position without configuration. In this case the respective standard bit rate is active for each equipped CAN transceiver (see following chapter 5 Seite 28).

4.4 Status LED

The status LED being located on the lower right of the front panel indicates the current operation status of the PCAN-MIO module by different colors and blinking frequencies.

Color	Blinking frequency	Operational status of the module
Red	Briefly on	Initialization of the module (power-on self test, POST)
	Permanently on	Hardware defect
Green	1 Hz (slow)	Normal operation with the configuration which is allocated to the currently specified module ID
	2 Hz (fast)	No or no valid configuration available for the currently specified module ID

5 Alternative CAN Transceiver Modules

The PCAN-MIO basic module comes equipped with High-speed CAN transceivers (from ser. no. 100 with wake-up function). On request, we can provide each CAN channel also with an alternative CAN transceiver module.

The PCAN-MIO module automatically detects the CAN transceiver module in use and provides the according transfer parameters.

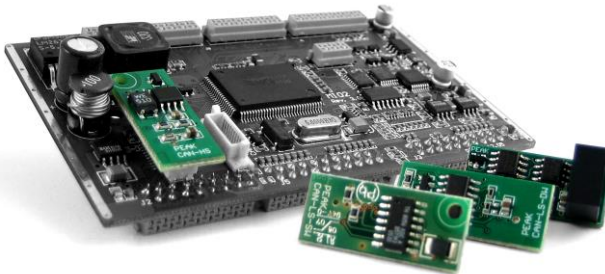

PCAN-MIO circuit board with plug-on transceiver modules

Following CAN transceiver modules are available:

Module name	Transmission standard	Special function	Default bit rate
CAN-HS	High-speed CAN ISO 11898-2		500 kbit/s
CAN-HS opto	High-speed CAN ISO 11898-2	Galvanic isolation up to 300 V for the CAN interface	500 kbit/s
CAN-HS-1041 (standard)	High-speed CAN ISO 11898-2	Wake-up	500 kbit/s
CAN-LS	Low-speed CAN ISO 11898-3	Wake-up	125 kbit/s
CAN-LS-SW	Single-wire CAN SAE J2411	Wake-up	33.3 kbit/s

6 Technical specifications

Power supply	
Supply voltage	9 - 27 V DC
Brownout check	Reset if internal 5-Volt supply < 4.35 V
Current consumption	60 mA typ. (without separate circuits) 100 µA in power-down mode
Reverse-polarity protection	Yes
Sensor power supply	5 V (max. -2 %), 500 mA

Digital outputs	
Count	8, 2 of them PWM-capable (DOUT0 and DOUT1)
Voltage proof	DOUT2 - DOUT7: Low-side 30 V
Constant current	DOUT0 - DOUT1: High-side 1.4 A DOUT2 - DOUT7: High-/Low-side 0.6 A per output (1.4 A together)
Short-circuit current	DOUT0 - DOUT1: 5 A DOUT2 - DOUT7: 1 A
Range for frequency generation	DOUT0 - DOUT1: up to ser. no. 99: 65 - 6000 Hz from ser. no. 100: 17 - 6000 Hz

Analog outputs	
Count	2
Voltage	0 - 10 V, each 20 mA (for internal reference voltage), other voltage range on request
Resolution	10 bit

Digital inputs	
Count	8
Switching thresholds	ON = 4 V, OFF = 3 V
Frequency range DIN0 - DIN4	5 - 10,000 Hz
Integration time constant	23 µs
Maximum input voltage	30 V

Continued on the next page

Analog inputs	
Count	6
Measuring range	0 - 10 V, other measuring range on request
Resolution	10 bit
Sample rate	1 kHz
Input impedance	13.6 k Ω
Integration time constant	1.6 ms
Maximum input voltage	30 V

CAN													
Standard transceiver	Up to ser. no. 99: High-speed CAN ISO 11898-2 (TJA1040) From ser. no. 100: High-speed CAN ISO 11898-2 with wake-up function (TJA1041)												
Other transceivers (on request)	High-speed CAN ISO 11898-2 (PCA82C251) without or with galvanic isolation Low-speed CAN ISO 11898-3 (TJA1055) with wake-up function Single-wire CAN SAE J2411 (TH8056) with wake-up function												
Wake-up time	typically 200 ms (depending on the size of the configuration)												
Termination	Setup with switches on the board <table border="1" data-bbox="476 970 845 1114"> <thead> <tr> <th>CAN</th> <th>OFF</th> <th>ON</th> </tr> </thead> <tbody> <tr> <td>High-speed</td> <td>none</td> <td>120 Ω</td> </tr> <tr> <td>Low-speed</td> <td>4.7 kΩ</td> <td>1.1 kΩ</td> </tr> <tr> <td>Single-wire</td> <td>9.1 kΩ</td> <td>2.1 kΩ</td> </tr> </tbody> </table>	CAN	OFF	ON	High-speed	none	120 Ω	Low-speed	4.7 k Ω	1.1 k Ω	Single-wire	9.1 k Ω	2.1 k Ω
CAN	OFF	ON											
High-speed	none	120 Ω											
Low-speed	4.7 k Ω	1.1 k Ω											
Single-wire	9.1 k Ω	2.1 k Ω											
CAN ID reserved for configuration transfer	7E7h												

Interference resistance	
Tests	IEC 61000 and DIN EN 61326 compliant
Peculiarity surge	± 500 V

Continued on the next page

Environment

Operating temperature	-40 - +85 °C (-40 - +185 °F)
Temperature for storage and transport	-40 - +100 °C (-40 - +212 °F)
Relative humidity	15 - 90 %, not condensing
Ingress protection (IEC 60529)	IP20

Measures

Size	130 x 65 x 35 mm (without connectors) See also dimension drawings in Appendix B Seite 34
Weight	max. 280 g

Appendix A CE Certificate

PCAN-MIO IPEH-002187(-A) – EU Declaration of Conformity
PEAK-System Technik GmbH



Notes on the CE Symbol

The following applies to the "PCAN-MIO" product with the item number(s) IPEH-002187(-A).

EU Directive This product fulfills the requirements of EU EMC Directive 2014/30/EU (Electromagnetic Compatibility) and is designed for the following fields of application as for the CE marking:

Electromagnetic Immunity/Emission

DIN EN 61326-1, publication date 2013-07

Electrical equipment for measurement, control and laboratory use – EMC requirements – Part 1: General requirements (IEC 61326-1:2012);
German version EN 61326-1:2013

Declarations of Conformity In accordance with the above mentioned EU Directive, the EU declarations of conformity and the associated documentation are held at the disposal of the competent authorities at the address below:

PEAK-System Technik GmbH

Mr. Wilhelm
Otto-Roehm-Strasse 69
64293 Darmstadt
Germany

Phone: +49 (0)6151 8173-20
Fax: +49 (0)6151 8173-29
E-mail: info@peak-system.com

A handwritten signature in black ink, appearing to read "Uwe W. Sch.".

Signed this 23rd day of January 2017

Appendix B Dimension Drawings

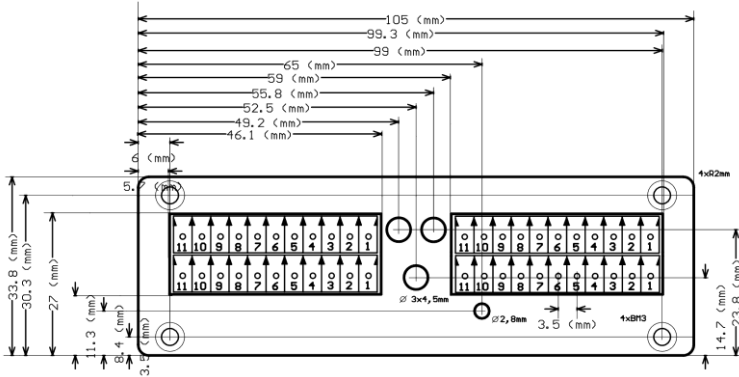

Front of the industrial model

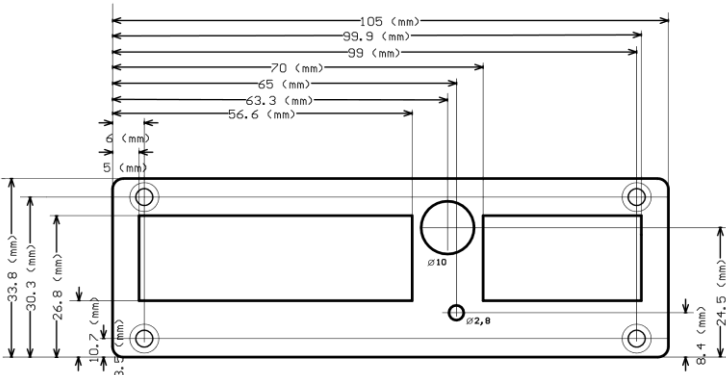

Front of the automotive model

Continued on the next page

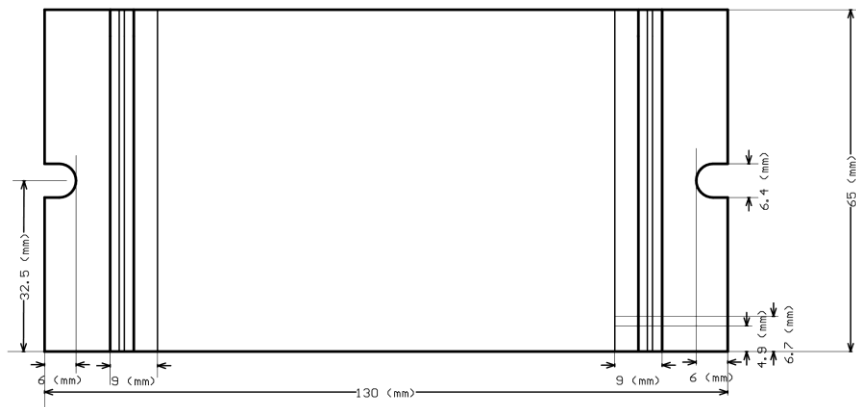

Top view of the bottom plate

The figures do not show the original size.

Appendix C Module Resources

The table lists all the logical resources of the PCAN-MIO module, arranged by I/O functions (column “I/O Function”) and the respective I/O numbers (column “I/O Number”).

I/O Function	I/O Number	Value range	Connection	Function
DOut Level (00h)				
	DO H0	0: open, 1: High	D4	High-side output 0
	DO H1		D5	High-side output 1
	DO H2		D6	High-side output 2
	DO H3		D7	High-side output 3
	DO H4		D8	High-side output 4
	DO H5		D9	High-side output 5
	DO H6		D10	High-side output 6
	DO H7		D11	High-side output 7
	DO HL2	0: Low, 1: High	D6	Push-pull output 2
	DO HL3		D7	Push-pull output 3
	DO HL4		D8	Push-pull output 4
	DO HL5		D9	Push-pull output 5
	DO HL6		D10	Push-pull output 6
	DO HL7	D11	Push-pull output 7	
	DO L2	0: open, 1: Low	D6	Low-side output 2
	DO L3		D7	Low-side output 3
	DO L4		D8	Low-side output 4
	DO L5		D9	Low-side output 5
	DO L6		D10	Low-side output 6
	DO L7		D11	Low-side output 7
DOut Frequency (01h)				
	Freq 0	Up to ser. no. 99: 65 - 6000	D4	Frequency output 0
	Freq 1	From ser. no. 100: 17 - 6000	D5	Frequency output 1

I/O Function	I/O Number	Value range	Connection	Function
DOut Ratio (03h)				
	PWM 0	0 - 255 (255 = 100 %)	D4	PWM output 0
	PWM 1		D5	PWM output 1
Generates a PWM signal with variable duty cycle and configurable frequency				
AOut Level (10h)				
	AOut 0	0 - 1023 (1023 = 10 V)	A6	Analog output 0
	AOut 1		A7	Analog output 1
10-bit D/A converter, I _a = 20 mA				
Special Out (70h)				
	Supply 5V	0: Off, 1: On	A8	5-Volt supply for external sensor I _a = 500 mA
	Selfhold	0: Off, 1: On		1 at power-on. To switch off the module set to 0.
	RS-232	0: Off, 1: On		1 at power-on. Switches the High stage for the pull-ups at the digital inputs, the reference voltage for analog in-/outputs, the RS-232 level converter.
	LED Pattern			(Reserved)
	CAN 0 Mode	0 - 5	CAN_L: B1, B3 CAN_H: B2, B4	Operation mode CAN transceiver 0
	CAN 1 Mode		CAN-L: A1, A3 CAN-H: A2, A4	Operation mode CAN transceiver 1
			SW-CAN: B2, B4	0: Normal (all transceivers) 1: WakeUp (AU5790) 2: PowerDown (AU7590, PCA82C251, TJA1041, TJA1055) 3: ListenOnly (PCA82C251, TJA1041, TJA1055) 4: HighSpeed (AU5790) 5: Standby (PCA82C251, TJA1041, TJA1055)
	Routing 0 to 1 All	0: Off, 1: On		Forwarding of all CAN messages
	Routing 1 to 0 All			
				from bus 0 to bus 1 from bus 1 to bus 0
	Debug Mode			(Reserved)
	Routing 0 to 1 Explicit	11-bit CAN ID, 29-bit CAN ID		Forward the specified 11-bit CAN ID
	Routing 1 to 0 Explicit			
				from bus 0 to bus 1 from bus 1 to bus 0
	Routing 0 to 1 Excluding	11-bit CAN ID, 29-bit CAN ID		Forwarding of all CAN messages except
	Routing 1 to 0 Excluding			the specified 11-bit CAN ID
				from bus 0 to bus 1 from bus 1 to bus 0
	CAN 0 Baud Rate Raw	0x0000 - 0xFFFF		Set the CAN baud rate by direct insertion of the register value into the baud rate register
	CAN 1 Baud Rate Raw			
	CAN Baud Rate: 33.3 kbit/s	0, 1 (CAN channel)		Specify a CAN baud rate
	CAN Baud Rate: 47.6 kbit/s			
	CAN Baud Rate: 50 kbit/s			
	CAN Baud Rate: 83.3 kbit/s			

I/O Function	I/O Number	Value range	Connection	Function
	CAN Bitrate: 95.2 kbit/s			
	CAN Bitrate: 100 kbit/s			
	CAN Bitrate: 125 kbit/s			
	CAN Bitrate: 250 kbit/s			
	CAN Bitrate: 500 kbit/s			
	CAN Bitrate: 1 Mbit/s			

DIn Level (80h)

Level 0	0: Low 1: High	C4	Digital input 0	
Level 1		C5	Digital input 1	
Level 2		C6	Digital input 2	
Level 3		C7	Digital input 3	Vih = 4 V
Level 4		C8	Digital input 4	Vil = 3 V
Level 5		C9	Digital input 5	
Level 6		C10	Digital input 6	
Level 7		C11	Digital input 7	

DIn Frequency (81h)

Freq 0	5 - 10000 (Hz)	C4	Frequency input 0	
Freq 1		C5	Frequency input 1	Frequency measurement
Freq 2		C6	Frequency input 2	Vih = 4 V
Freq 3		C7	Frequency input 3	Vil = 3 V
Freq 4		C8	Frequency input 4	

DIn Ratio (83h)

Ratio 0	0 - 1000 (1000 = 100 % High)	C4	PWM input 0	
Ratio 1		C5	PWM input 1	Measurement of the duty cycle (high phase)
Ratio 2		C6	PWM input 2	Vih = 4 V
Ratio 3		C7	PWM input 3	Vil = 3 V
Ratio 4		C8	PWM input 4	(only to 1 kHz)

I/O Function	I/O Number	Value range	Connection	Function
DIn Low Frequency (86h)				
	Low Freq 0	1 - 10000 (0.001 Hz)	C4	Digital input 0
	Low Freq 1		C5	Digital input 1
	Low Freq 2		C6	Digital input 2
	Low Freq 3		C7	Digital input 3
	Low Freq 4		C8	Digital input 4
Low frequency measurement (0.001 - 10 Hz) V _{ih} = 4 V V _{il} = 3 V Sample each millisecond, calculation each 10 milliseconds				
Pull-Up/Down (88h)				
	Pull-Up 0; 1-3; 4; 5-7	0: deactivated 1: activated	C4...C11	Pull-up resistor for digital input or digital input group
	Pull-Dn 0; 1-3; 4; 5-7			Pull-down resistor for digital input or digital input group
Pull-up/pull-down resistors each 4.7 kΩ. This I/O function is only available in the hardware profile "PCAN-MIO (32-Bit)" (from ser. no. 100).				
AIn Level (90h)				
	AIn 0	0 - 1023	B6	Analog input 0
	AIn 1		B7	Analog input 1
	AIn 2		B8	Analog input 2
	AIn 3		B9	Analog input 3
	AIn 4		B10	Analog input 4
	AIn 5		B11	Analog input 5
Input range: 0 - 10 V Hardware low-pass: 6.8 kΩ, 33 nF				
Tau (98h)				
	Tau 0	0 - 60000 (ms)		Time constant for analog input 0
	Tau 1			Time constant for analog input 1
	Tau 2			Time constant for analog input 2
	Tau 3			Time constant for analog input 3
	Tau 4			Time constant for analog input 4
	Tau 5			Time constant for analog input 5
Software low-pass for analog inputs				
Const (CCh)				
	(See list in the PPCAN-Editor)	(Diverse values)		Diverse constants Read only; can be used as input constants.
Positive Const (CDh)				
	0 to 255	(0 to +255)		Positive constants Read only; can be used as input constants.

I/O Function	I/O Number	Value range	Connection	Function
Negative Const (CEh)				
	0 to -255	(0 to -255)		Negative constants Read only; can be used as input constants.
Special In (F0h)				
	Conf Ver Main	0 - 255		Main version number of the configuration Version of the configuration; can be specified in the PPCAN-Editor during the module-specific settings
	Conf Ver Sub	0 - 255		Secondary version number of the configuration
	FW Ver Main	0 - 7		Main version number of the firmware For information purposes; read only
	FW Ver Sub	0 - 31		Secondary version number of the firmware
	FW Build	0 - 255		Build version number of the firmware
	Module ID	0 - 15		Module ID Position of the corresponding rotary switch on the PCAN-MIO module; ID must be unique within the CAN net.
	Main Cycle Counter	0 - 65535		Count of computation cycles of the firmware since the last call; read only
	Main Cycle Time Max			Maximum duration in ms for a computation cycle since the last call; read only
	Main Cycle Time Avg			Average duration in μ s for a computation cycle since the last call; read only
	none			No function Can be used as place-holder if the corresponding input or output has no function.
32bit Variable (FFh)				
	0 to 255	32 Bit signed		Internal 32-bit variable Temporary memory for values of function blocks and CAN variables